



CARBON PRINTING



Photographic printing process developed in 1855, and adapted in 2010 to current products and equipments by René Smets

INTRODUCTION:

Carbon printing is a photographic process the foundation of which was laid in 1855 by Alphonse Poitevin.

The process relies upon the ability of an organic material (gelatin) to become insoluble in water when sensitized with dichromates and exposed to sunlight.

A substrate (carbon tissue) is coated with a layer of gelatin mixed with pigment, and sensitized with potassium dichromate. A contact print is made under a large negative. The gelatin layer is then transferred to a carrier, and developed.

This development is done by rinsing away the gelatin that was not hardened by light. The result is a relief layer of gelatin, showing the full tonal scale of the negative, from paper white to maximum black, on the final paper support.

Carbon printing is one of the few processes rendering all the details of the negative in the final print.

Explanations of the above will be based on texts, pictures and drawings. Don't be impressed by the sometimes complicated equipment I built for this; everything can be carried out in a simple way, using simple tools.

I have been working for months on the whole process, but considerable time was spent on the more or less successful building of several pieces of equipment. The taking of pictures, their digital processing and several drawings also took quite some time.

I did thoroughly enjoy this, and am very pleased to share my findings with all those interested in the process. Questions are welcome at any time, and I'll try to answer them to the best of my abilities.

The process will be explained in seven stages, each of them being presented with its own description, formulas, pictures and drawings.

The seven stages are:

1. making a large negative
2. sizing watercolour paper
3. mixing and coating a pigmented gelatin layer
4. sensitizing
5. exposure
6. developing
7. drying
8. finishing

1. MAKING A LARGE NEGATIVE:

In the early days of carbon printing, large negatives were not a problem, as the cameras in use were mostly large format.

Currently, large negatives can be computer made, but I still have to see the large digital negative fitting my needs for various alternative processes and keeping their cost (printer, inks) at a reasonable level.

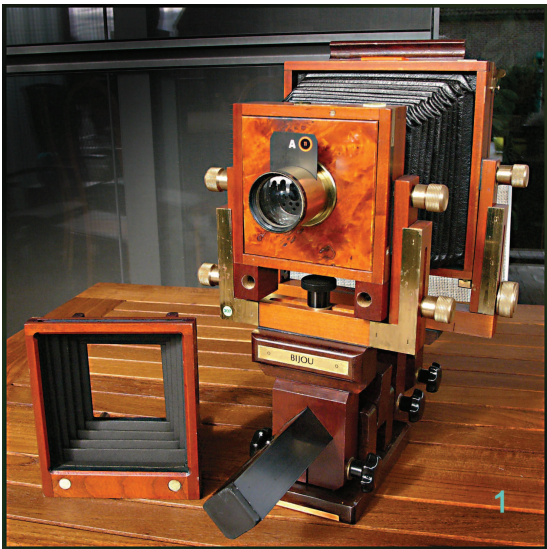

The urge for sticking as much as possible with the traditional methods was so powerful, that I decided to build my own 4'x5' camera.

(fig. 1)

In order to be able to make even larger negatives, I bought some old cameras on used equipment markets. I refurbished these cameras and adapted their film holders to the modern sheet films

(fig. 2 and 3)

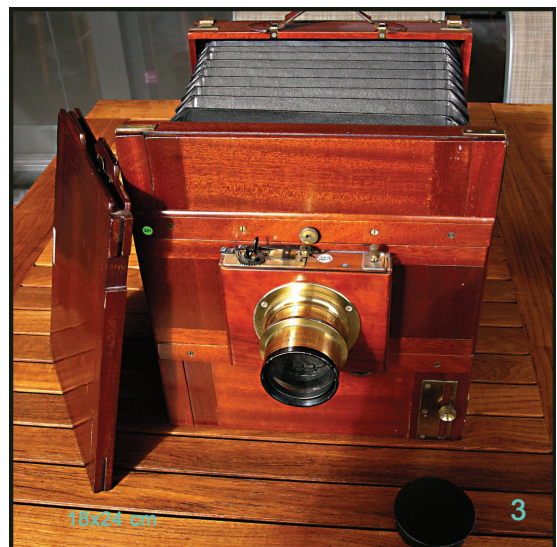

Using these cameras is the easiest way to get a large negative; let's see the hardest way now..

After some years of activity, every amateur photographer is owning a serious number of negatives, either 24x36mm or 6x6cm. How to make large negatives from these small ones is shown below.

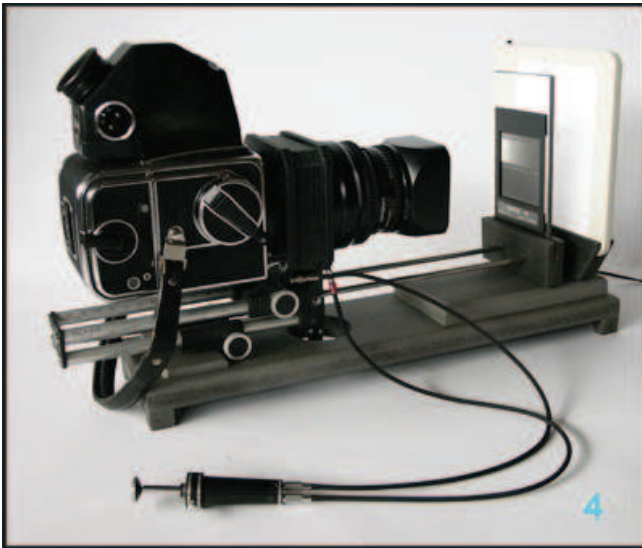

Under my camera and its bellows, I built a sliding support where bellows and negative holder can be mounted solidly and free from any vibrations.

(picture #4).

I completed the system with a small light box and with a negative holder that can be moved in order to allow pictures to be taken at 1x1 ratio.

Using this light box ensures that the light intensity always is the same, and therefore also the corresponding exposure time, as long as the density of the negatives remains the same.

(see sketch 1)

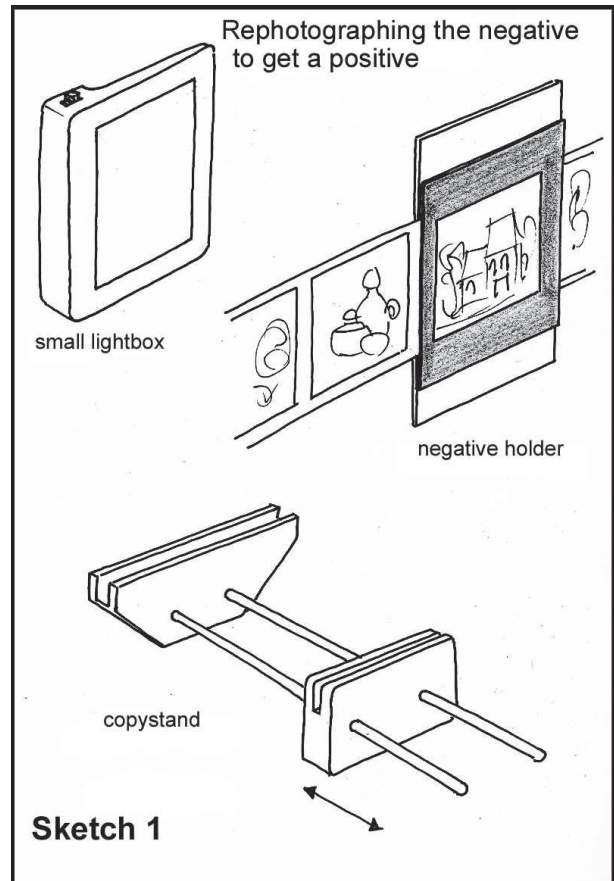

To record the positive, I use Rollei Pan 25 film (25 ISO).

After some testing with a step tablet (Stouffer) it is possible to determine the exact exposure which will produce a good positive showing full details in the shadows as well as in the highlights, provided they were in the original negative.

The film is processed in ROLLEI RHS developer, diluted 1+7, during 5min.30sec. at 20°C. That is about 10% more than the manufacturer's recommendations, in order to get full details in the whole negative.

These positives are then enlarged under the enlarger, in just the same way than making a paper print. The only difference is that the film is exposed on a black background rather than a white one.

Some years ago, continuous tone films similar to the variable contrast Gevarex were still available. These are gone now. It was possible to manipulate them under red safelight. The currently available orthochromatic films should be adequate for this use too, but until now I haven't done any testing with them. I use ADOX CHS panchromatic film (25 ISO) for making my large negatives.

This film is a normal film for picture taking purposes, and therefore rather fast. So I had to equip my enlarger with a shutter between negative and lens, as very short exposure times are necessary.

(see pictures # 5, 6 and 7)

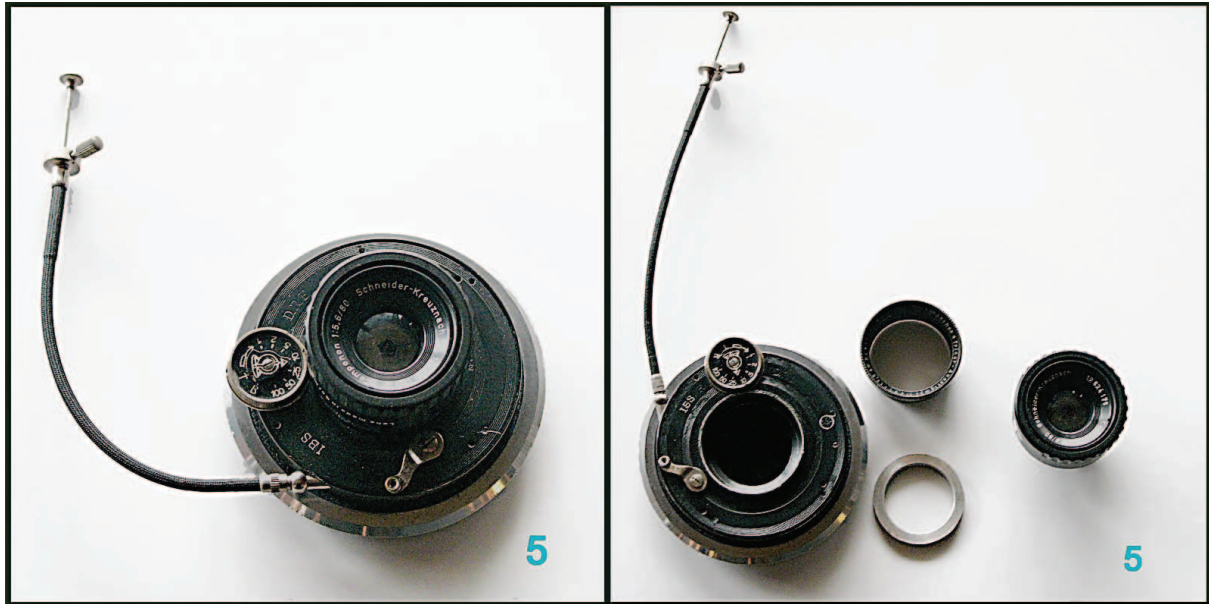

Every single light leak has to be eliminated on the enlarger, as the film has to be manipulated in complete darkness.

I use to process these large negatives in trays, just as prints; but sometimes I use a self-built container which makes it possible to process several negatives



together (see picture # 8).

Contrast can be steered by adapting the developer concentration and development time.

It is recommended to use a printing frame, preferably equipped with registering pins, on the baseboard of the enlarger for exact positioning of the film, as all the work has to be done in complete darkness.

I built two such frames, one being somewhat more sophisticated than the other.

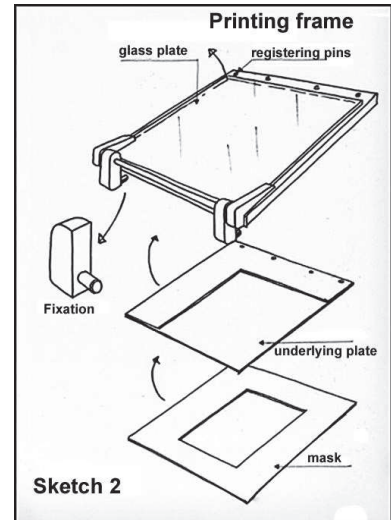

Sketch 2 shows the first one, which has a base that can be fixed with pins to the enlarger's baseboard.

This base is fitted with four registering pins for the positioning of masks and films. A pivoting glass plate provides the necessary pressure on the whole.

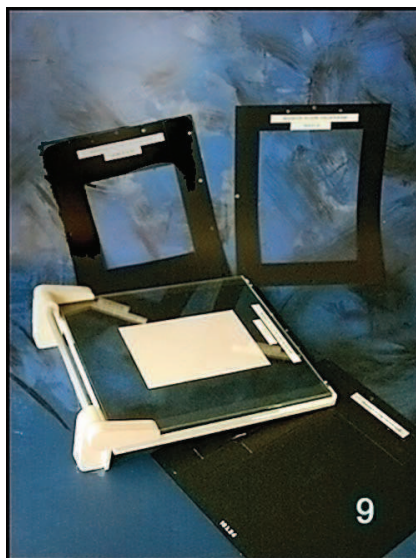

Unlike photographic paper, film has to be exposed on a black background. The usual white base of most enlarging easels is inadequate. Finally, I have cut various masks corresponding to the film formats I use (see picture # 9).

These accessories make it a snap to position precisely the film under the enlarger.

Finally, I keep the exposed films in a light-tight drawer while working.

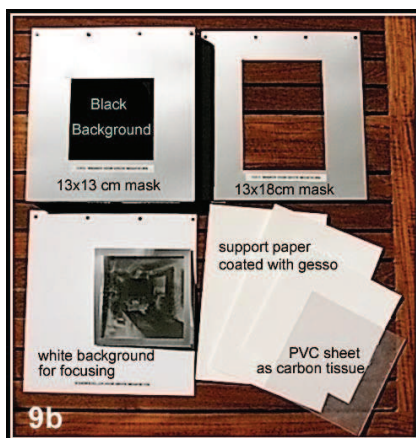

The second, somewhat simpler frame basically is a board on which four registering pins were glued. The surface was painted black. For focusing, I use a white sheet of pvc that fits on the registering pins.

Depending on its format, the large negative is placed in the corresponding mask, which then is placed on top of the surface to be exposed for contact printing. The masks were cut in 0,2mm thick aluminum sheets that I got from a printer.

Remark: The support papers displayed in picture #9b were sized with Gesso, which guarantees good flatness.

As for the carbon tissue, I do often use clear pvc sheets sanded on one face to make it matte, instead of paper. Pvc has the advantage of being indefinitely reusable, and of staying perfectly flat.

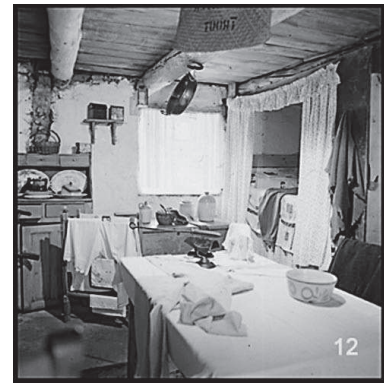
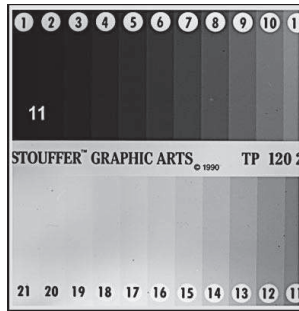
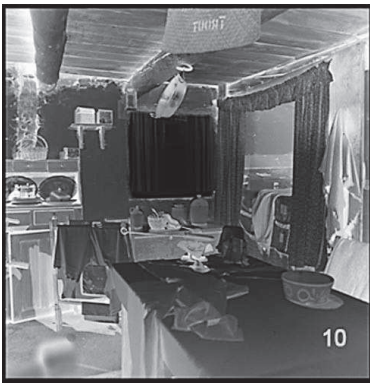

Picture #10 shows a 6x6cm (2.25"x2.25") negative with good detail in both shadows and highlights. Picture #11 shows a positive print of a Stouffer step tablet. it is used to evaluate exposure and development; when they are correct there is a distinct difference between steps #1 and 2 as well as between #20 en 21. Picture #12 shows one of the positives which got an accurate exposure and development time. Picture #13 shows a partial scan of a big negative made on ADOX CHS film.

CAUTION!

As for carbon printing, it is of utmost importance that the support paper is larger than the carbon tissue (see sketches)

- A. The negative has an opaque border that does not let any light passing through; this will prevent the pigment layer to be washed out. The negative is the smallest part. With its borders, it may be of the same size than the carbon tissue.
- B. The carbon tissue is at least as large as the negative, borders included.
- C. The support paper is somewhat larger than the carbon tissue on all sides.

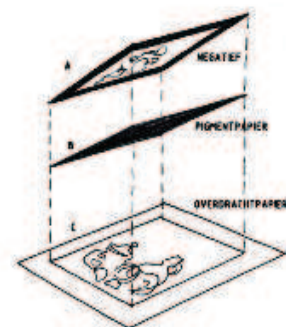
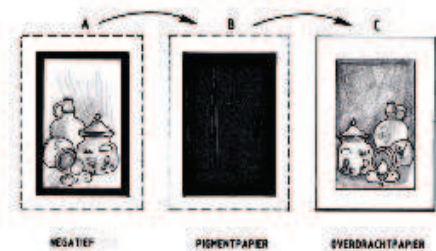

2. SIZING THE WATERCOLOUR PAPER

The paper I'm using is Arches aquarelle hot pressed grain satiné which is 300 gr./sqm (see picture #14).

In order to prevent the pigments from penetrating into the fibers of the paper, which would result in grayish white parts, the fibers have to be saturated with gelatin.



The normal household gelatin in sheets is used for this.

In order to prevent the gelatin from being flushed away in the following baths, it has to be hardened with chrome alum (see picture #15).

I use the formula below:

- water 1 liter
- gelatin 50 gr.
- chrome alum 5 gr. in 100 ml water

I mix 2 cc of this solution per 100 ml of gelatin solution, i.e. 20 cc per liter.

The gelatin is soaked in cold water for about 30 min. and then warmed in a bain-marie until it dissolves completely.

Simultaneously, the chrome alum solution is warmed too, and then stirred into the hot gelatin.

In order to size easily a significant number of papers, I use a warming plate on



which I put an aluminum tray, on one face of which is fixed a spring-loaded bar. The moist paper is pulled between this bar and the edge of the tray, which eliminates air bells as well as the



excess of gelatin (see pictures #16a and 16b).



The paper is left for a couple of minutes in the gelatin before the sheets are taken out one by one and suspended to dry (see picture #18).

The sizing is repeated twice in order to be sure that the fibers are completely saturated.



MY GESSO METHOD

When painting with oil paints on paper, I apply a Gesso primer. I tried this also on a carbon tissue, and the result were astonishing. The white parts are beautifully white, and the pigmented gelatine adheres very well.

This is how I proceed:



a watercolour paper is put on a varnished plate and moistened thoroughly on one face. The paper is left until completely straightened.

In the meantime, all air bells are continuously wiped away with the sponge.

The paper is then fixed on the plate with a special tape, that sticks when moistened (see pictures A and B).

The entire sheet is now coated with Gesso: a

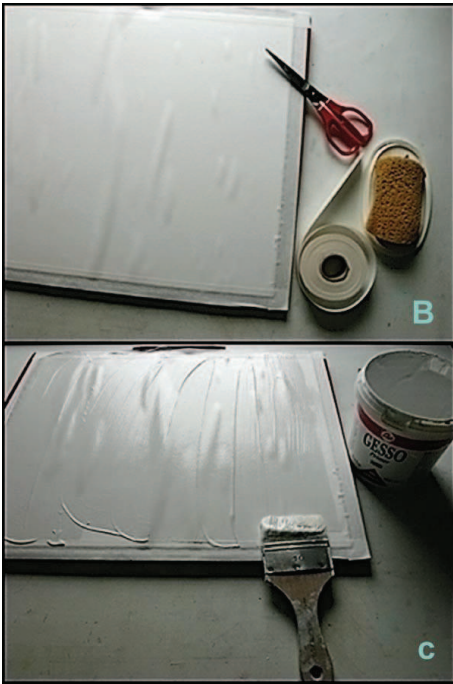

brush is gently stroked in all directions in order to get an even distribution.

When the product is evenly spread, the layer is equalized with a very soft brush stroked in all ways (see pictures C and D).

Very gentle brush strokes will ensure a beautiful, even layer of Gesso (see picture E).

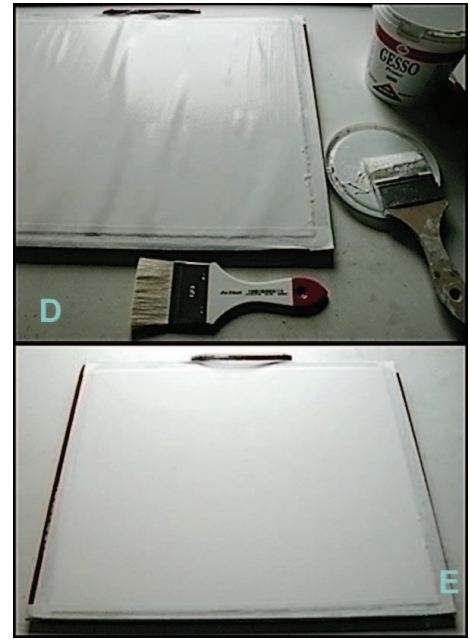

After a couple of hours, the paper is completely dry and outstretched. I get very nice results with this technique.

There might be criticisms, as this is not respecting the original way of doing. I fully agree, but in my opinion, what's important is the final result. Digital negatives are also miles away from the original technique, after all...

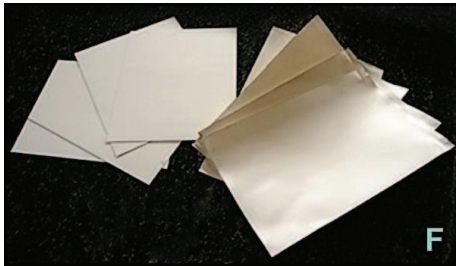

Picture F shows the result after drying.

The gelatin-sized papers show creases from the hanging pins, aren't flat and are far less white than the Gesso papers.

The latter are perfectly flat and present a quite even white surface, very pleasant to work with.

3. MIXING THE PIGMENTED GELATIN AND COATING

To make the carbon tissue, the products shown in picture #19 are used in following proportions:

water	250	ml.
gelatin	30	gr.
candi sugar	12,5	gr.
fish glue	5	ml.
glycerin	5	ml.
agepon	2	ml.
ivory black	15	gr.
lime blue	1	gr.
Vandyck brown	4	gr.
gum arabic	2,5	gr.

The candi sugar has to be ground quite finely in a blender. After this, part of the water is heated and the sugar dissolved in order to avoid the subsisting of any grains which would be visible in the emulsion layer.



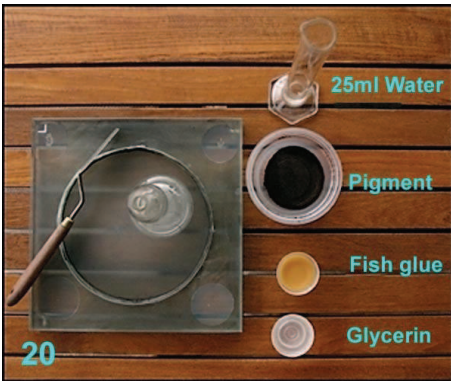

The powder pigments cannot just be mixed with the liquids. They have to be crushed with a little liquid, as shown on picture #20.

25 ml. of the above mentioned water is used to crush the pigment on a sanded glass plate with the fish glue and the glycerin (see picture # 21).



At the beginning, the pigment floats on the liquid, but after some time (about 20 min.) one gets a quite liquid, homogeneous pasta (see picture #22).

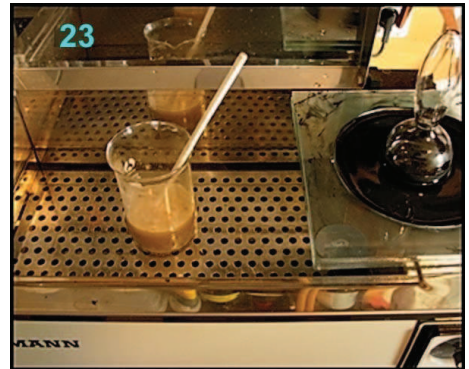

The gelatin, sugar, gum arabic and Agepon wetting agent are poured in the cold water, stirred from time to time during 30 minutes.

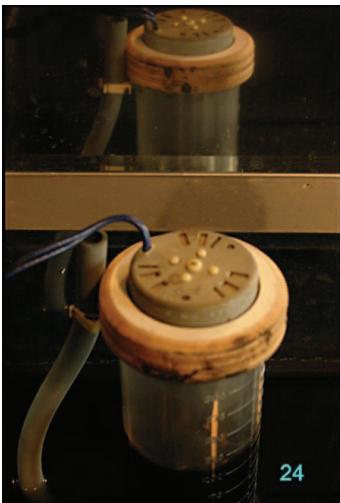

The liquid is then warmed in a bain-marie until the gelatin becomes liquid (see picture #23).

The crushed pigment mixture is also warmed before being added to the gelatin. The liquid is filtered and stirred for 2 hours. I build an electric mixer for this (see picture #24).



The mixer is placed on top of a measuring glass at the bottom of which a tapping hose has been fitted. This allows to take the liquid while the possible air bells remain at the surface (see picture #25).



The paper I'm using is Canson Bristol (see picture #26).

Sketch 1 shows the accessory I built for crushing the pigment. It is made from a sanded glass plate on top of which is fixed another glass plate of 8mm. thickness with a round hole of 18 cm, the whole being sealed with silicon.

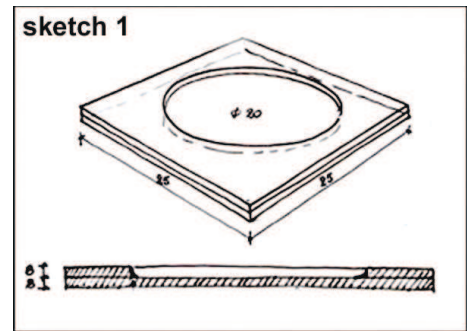

POURING THE PIGMENT COAT.

It is advised to use sheets of plain foodstuff gelatin, which has a lower melting point than photographic gelatin.

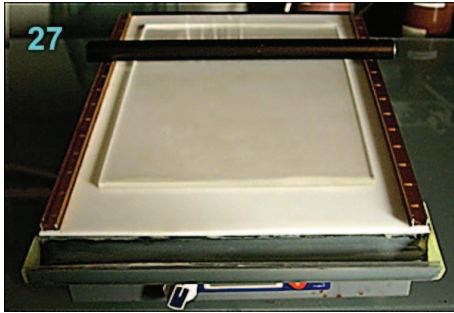

In order to make the coating easier, an accessory was built. It is composed by a plate in plexiglass on both sides of which were fixed aluminum profiles which will determine the thickness of the coat. In the middle of this is sitting a removable plexi plate on which the paper is to be laid (see picture #27).

This accessory is placed on a warming plate, and once the whole is at temperature, the coating can begin.

The paper to be coated is soaked for a couple of minutes in cold water. Then the water in excess is wiped off the sheet, the paper laid on the plexi plate and squeegeed to complete flatness.



Due to the moist, the paper adheres well to the plexi plate. The upper face of the paper is dabbed to remove every trace of liquid. (See picture #28).

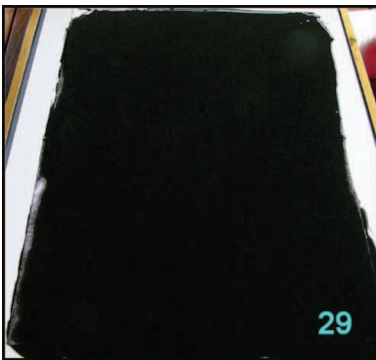

The gelatin-pigment mixture is then poured on the paper and evenly spread out with a few movements of an aluminum rod.

As the mixture is warm, it's easy to spread. A cold glass plate is then slipped under the coated paper, and the whole is put aside (keeping it perfectly horizontal) until the coating congeals (see picture #29). This way, a nice, even, shiny coat is obtained (see picture #30).



After the coating, all sheets are suspended for drying (see picture #31).

With the above mentioned quantities, I coat 8 A4 sheets.



4. SENSITIZING

The carbon tissue is sensitized with a 3% solution of potassium dichromate. Here is how:

The dry pigment paper is soaked in water until it becomes perfectly flat (picture #32).

Water in excess is wiped off (picture #33).

The temperature of the dichromate bath is set around 15°C.

The paper is weltered fo 3 minutes in the dichromate solution (picture #34).

Then the paper is wiped again, as shown on picture #32.

Finally, the sheets are hung to dry.

The drying can be speeded up with a fan set on "cold" (picture #35).

5. EXPOSING

A carbon print can be perfectly exposed to daylight; but as this light can be quite unstable, the resulting exposure times might be unpredictable and changing. It is therefore advisable to expose to UV light using a 120 watt Philips HPR lamp or a light unit with UV TL lamps.

I have built such a light unit with six tubes of 20 watt, as shown in the following pictures (see pictures #36 and 37).

Personally, I use the HPR lamp with preheating device.

The correct exposure has to be found by testing.

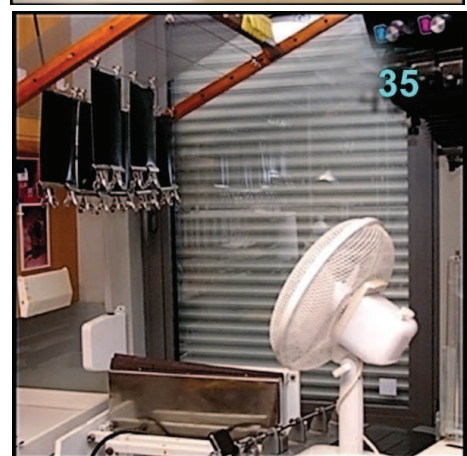
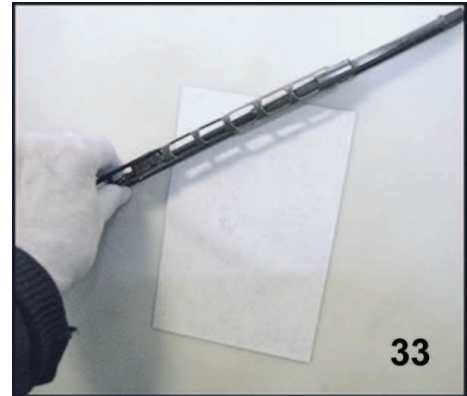

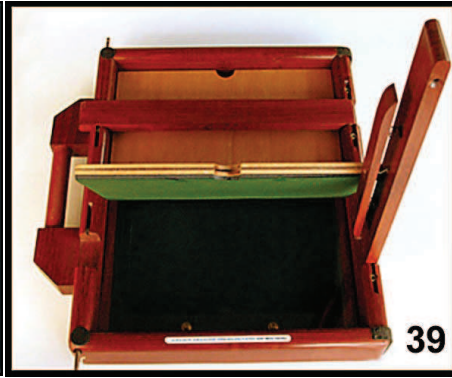
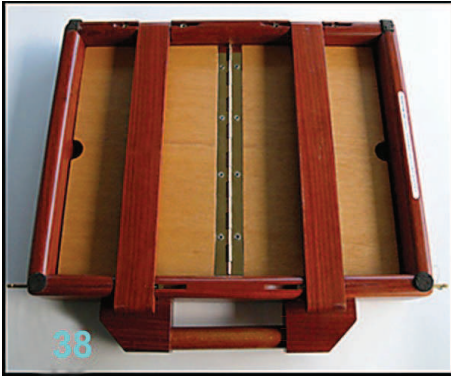

To give you a starting point for your own experiments: I use to expose for four minutes at a distance of 40 cm.

The work is easier when using a printing frame with registering pins, as this allows fast and accurate positioning of paper and film (pictures #38 and 39).

Here you can see how the carbon tissue is exposed under the HPR lamp (picture #40).

Before the exposure, the support paper is soaked for about ten minutes in cold water (picture #41).

After exposure, the carbon tissue is immersed in the same water bath until the paper is fully stretched out (picture #42).

When the support paper and carbon tissue are both under water, both front sides have to be rubbed gently with a soft brush, to eliminate invisible bells formed by the air which is always present in water.

When this isn't done, you are at risks to have airbells in your sandwich.

Both papers are then put face to face under water, and subsequently pressed together on a plexi plate with a squeegee (picture #43).

This sandwich is pressed tightly using a roller, from the centre towards the sides (picture #44).

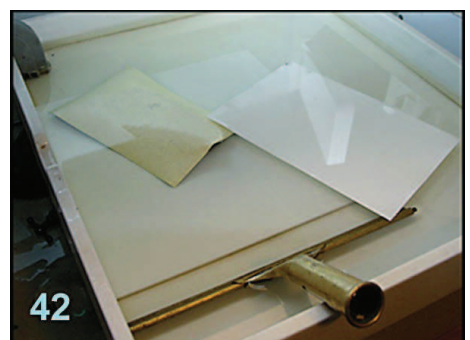
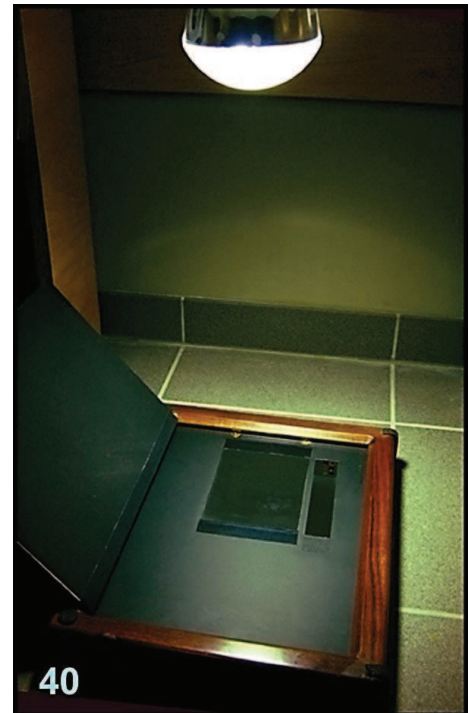

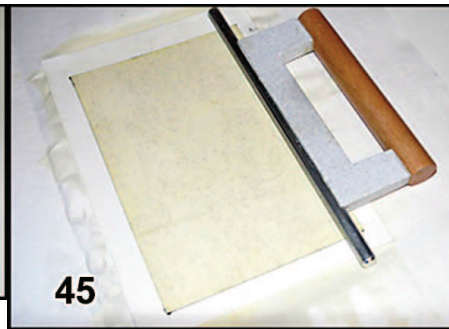
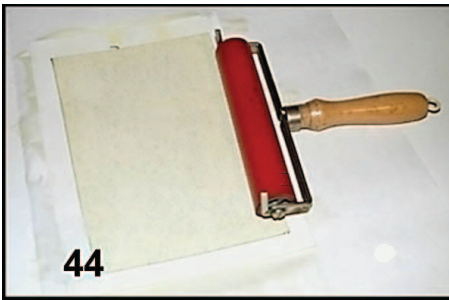

To get an even better pressure on a small surface, I built my own squeegee (picture #45).

Finally, the sandwich is put for about 15 minutes under a weighted flat plate. (see picture #46)

6. DEVELOPING

After that time, the sandwich is slipped cautiously, without crumpling, into a water bath of about 40 °C.

(pictures 47 and 48)



The pigment tissue is on top; after a while, one can see the pigment-loaded gelatin starting to melt all around the pigment tissue. That takes a few minutes (3 to 4).

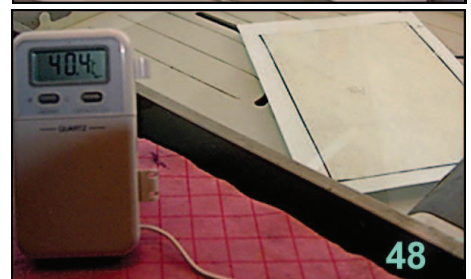

Both papers are then separated in one continuous movement (picture 49).

Discard the pigment tissue and keep the support paper in the warm water bath.



Move the paper gently back and forth and turn it with the gelatin layer down.

Leave it alone for a few minutes; this can take about 15 minutes (picture 50).

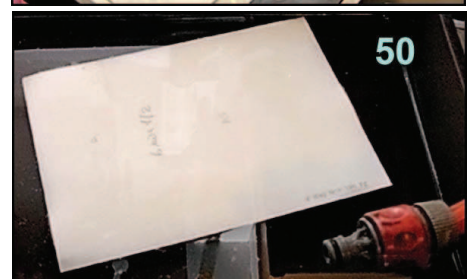



After this interval, the gelatin that wasn't hardened is washed away and the image appears in all its glory (picture 51).



7. DRYING

Hang the paper on a vertical plane; when there isn't any pigment coming off, the processing is completed and the print can be hung to dry. (picture 52)

René Smets
May 2010
(new version April 2011)
translation: J. Kevers

Picto Benelux

Picto is an informal group, open to everybody in the Benelux who has an active interest in any photographic processes developed from the very beginning of Photography. The aim is to revisit them, while respecting anyone's creative approach.

<http://www.picto.info/>